

| PARTS LIST | | | | | |
|------------|------------|---------------------------|---------------|-------------|----------|
| ITEM | QTY | PART NUMBER | DESCRIPTION | MATERIAL | MASS |
| 1 | 1 | Botnplata 250x250 | | Steel, Mild | 2.943 kg |
| 2 | 4 | Styrking 75x75x5 | | Steel, Mild | 0.110 kg |
| 3 | 300.000 mm | CFRHS 50 x 50 x 5 - 300 | Tube | Steel, Mild | 2.009 kg |
| 4 | 300.000 mm | CFRHS 40 x 40 x 5 - 300 | Tube | Steel, Mild | 1.460 kg |
| 5 | 1 | DIN 555-5 - M12 | Hex Nut | Steel, Mild | 0.017 kg |
| 6 | 1 | DIN 960 - M12 x 1,25 x 65 | Hex-Head Bolt | Steel, Mild | 0.076 kg |
| 7 | 2 | Plata 50x30 | | Steel, Mild | 0.058 kg |

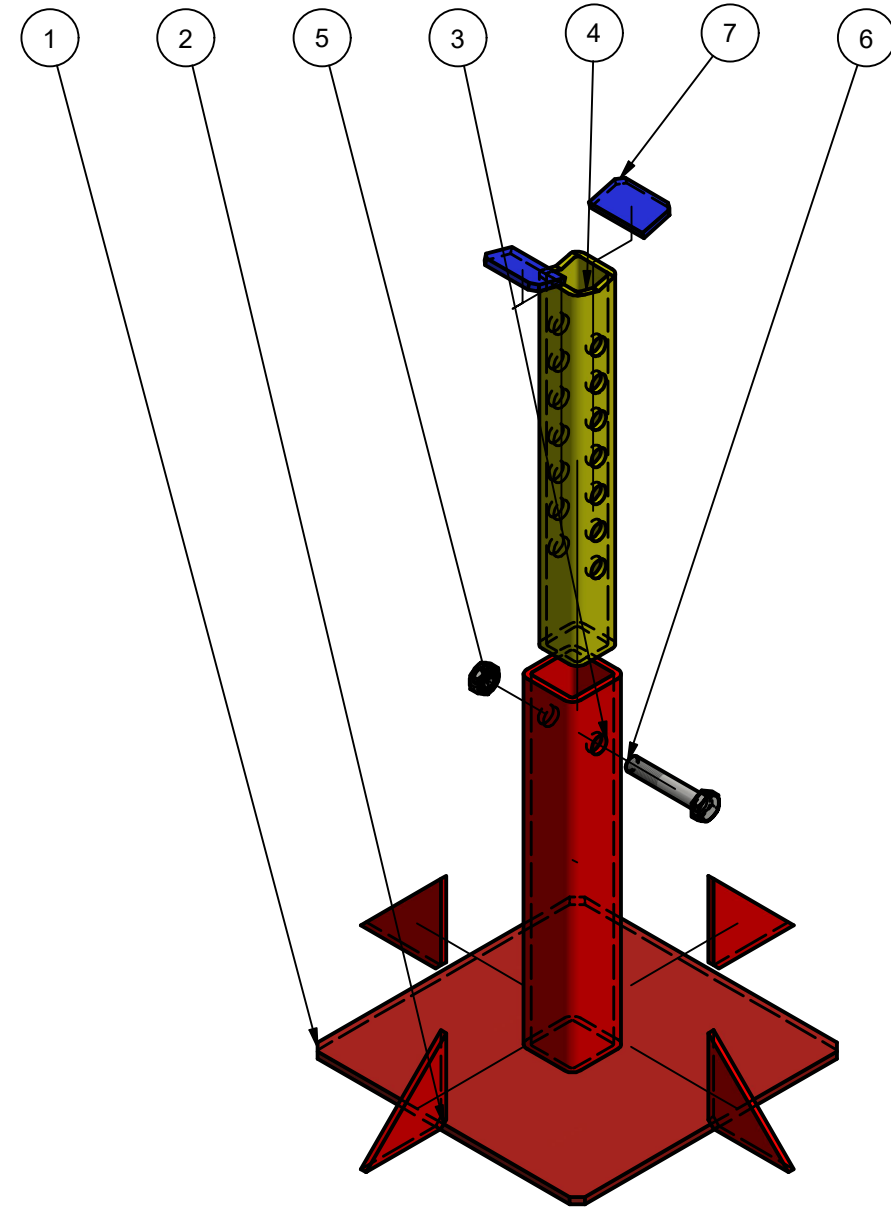
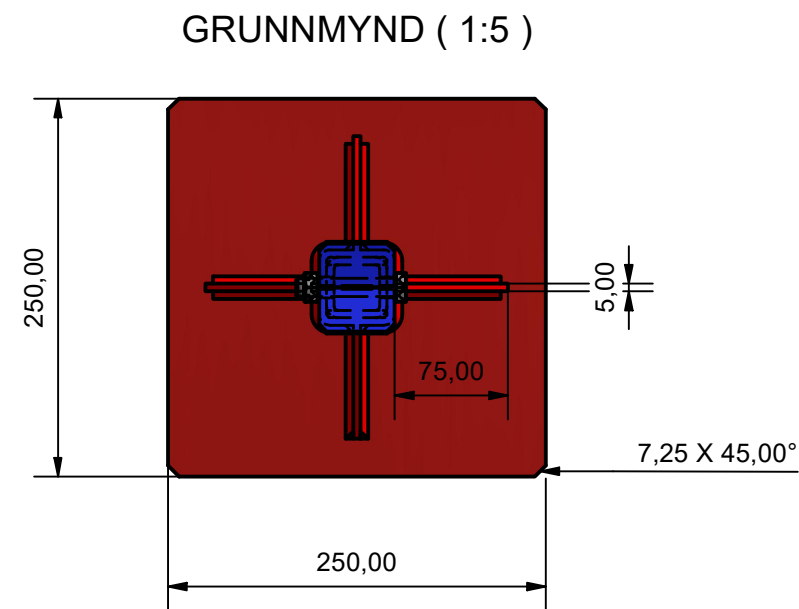
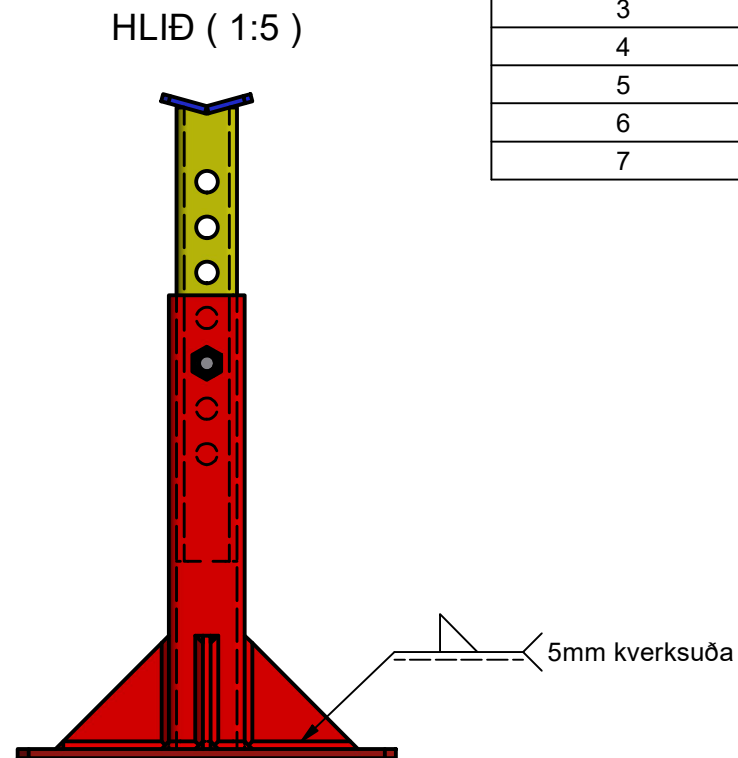
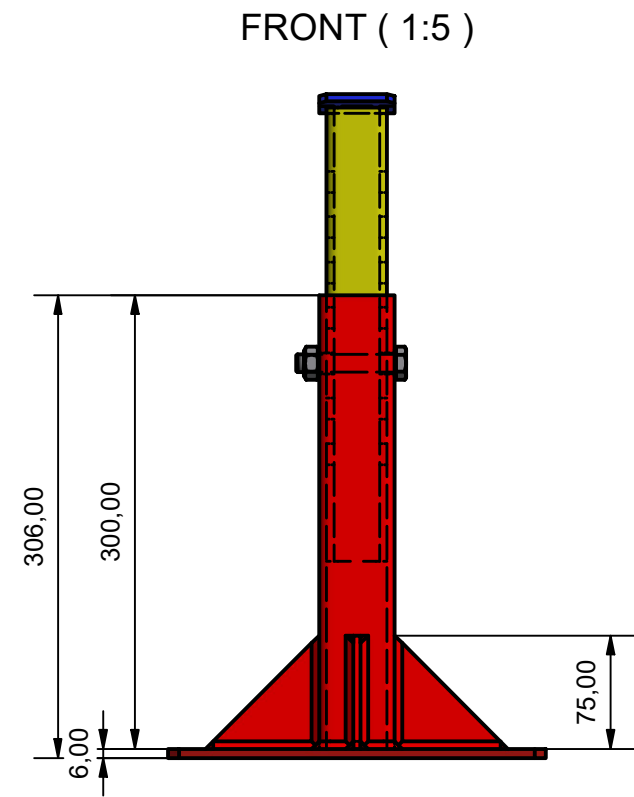

LEIÐRÉTT: 06.05.2020

| | | | | |
|---|-------------------|-----------------------|--|--------------------|
| TickCad ehf - Skúlagata 10, 101 Reykjavík. www.tickcad.is - tickcad@tickcad.is - tel: 5523990 | | | | |
| Designed by Finnur P | Sheet Size: A3 | Scale: 1:5 | All measurements in mm except if otherwise stated DO NOT SCALE | Date 05/02/2014 |
| | | IDAN FRÆDSLUSÆTUR | | |
| | | Part Number: Búkki | Edition 1 | Sheet 1 / 2 |

CFRHS 50 x 50 x 5 - 300 (1 : 2)

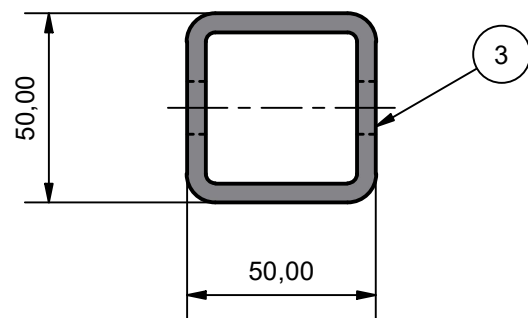
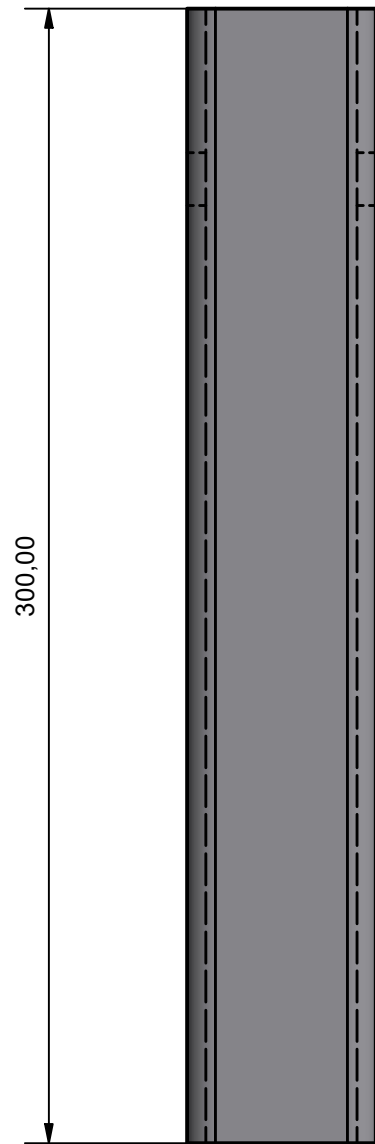

CFRHS 40 x 40 x 5 - 300(1 : 2)

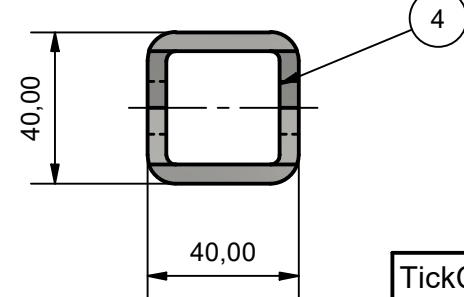
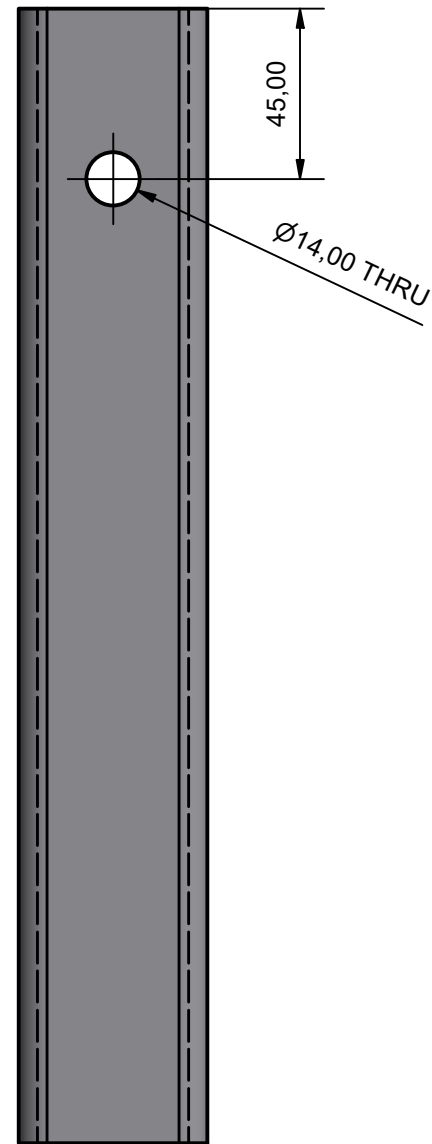

LEIÐRÉTT: 06.05.2020

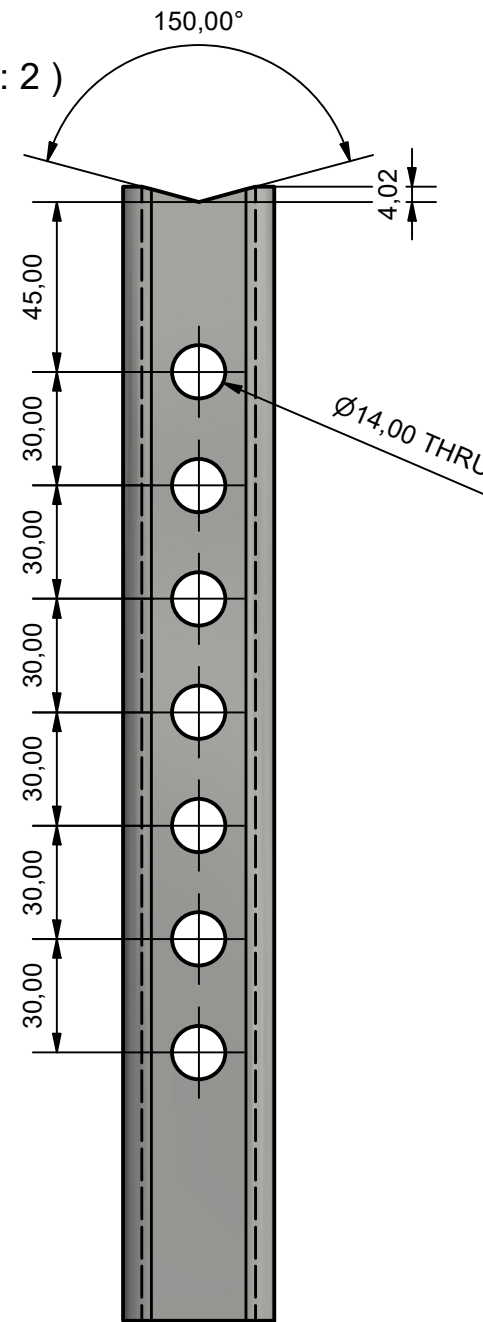

Plata 50x30 (1 : 2)

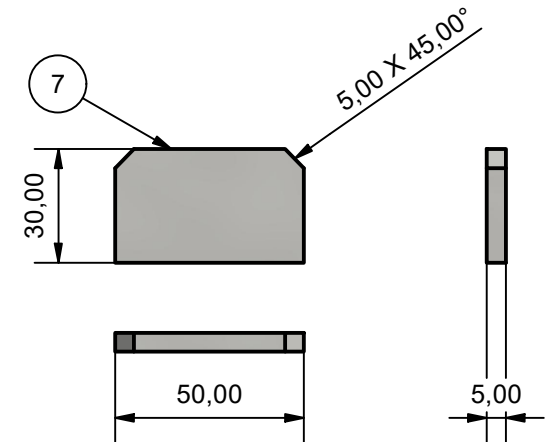

Styrking 75x75x5 (1 : 2)

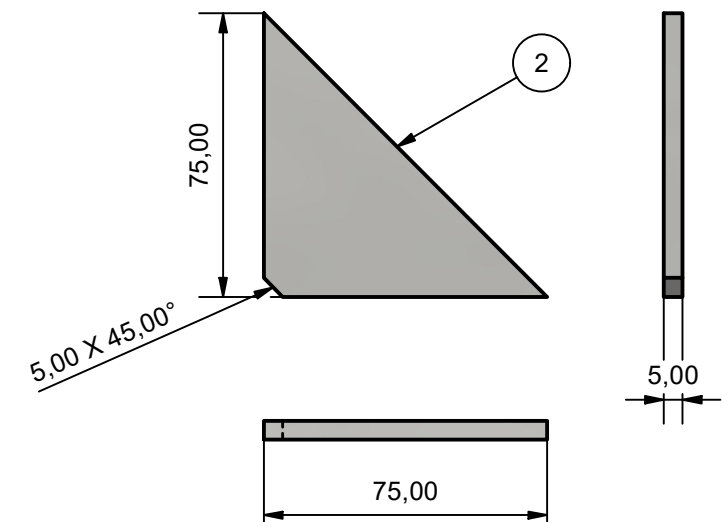

TickCad ehf - Skúlagata 10, 101 Reykjavík. www.tickcad.is - tickcad@tickcad.is - tel: 5523990

| | | | | |
|-------------------------|-------------------|-----------------|--|--------------------|
| Designed by Finnur P | Sheet Size: A3 | Scale: 1 : 2 | All measurements in mm except if otherwise stated DO NOT SCALE | Date 05/02/2014 |
|-------------------------|-------------------|-----------------|--|--------------------|

| | | | |
|--|---|--------------|----------------|
| | ÍÐAN FRÆÐSLUSETUR BÚKKI | | |
| | Part Number: CFRHS 50 x 50 x 5 - 300 | Edition 1 | Sheet 2 / 2 |